

Enhanced Detection of Mercury Using the CETAC HGX-200 Cold Vapor / Hydride Generator with Quadrupole ICP-MS Detection



Figure 1. CETAC HGX-200 Cold Vapor/Hydride Generator

Introduction:

The detection of mercury by quadrupole ICP-MS using conventional pneumatic nebulization can suffer from a number of limitations: the longer washout time of volatile Hg^0 , the relatively high Hg ionization energy (10.4 eV), and potential interferences from tungsten oxides (WO^+) on the major Hg isotopes (^{199}Hg , ^{200}Hg , ^{202}Hg).

An alternate sample introduction technique that can address the latter two limitations is cold vapor generation of Hg^0 . A sample solution containing Hg is mixed on-line with a solution of stannous chloride (SnCl_2). The resulting reaction will reduce Hg^{2+} to volatile elemental Hg^0 that is swept by a carrier flow of argon gas to the ICP-MS. This technique can offer up to 100 percent sample transport efficiency (vs. <5 percent for conventional pneumatic nebulizers) to markedly increase Hg sensitivity despite the higher ionization energy. The specificity of the reaction will also separate Hg from any nonvolatile interferences such as a WO^+ .

CETAC HGX-200 Cold Vapor/Hydride Generator:

The CETAC HGX-200 Cold Vapor/Hydride Generator (Figure 1) is equipped with solution mixing blocks and a specialized Gas-Liquid Separator (GLS) with a "frosted" glass post. This post provides a high surface area for release of Hg^0 or volatile hydrides. The GLS also features a porous polytetrafluoroethylene (PTFE) membrane and droplet separator for complete gas-liquid separation and reduction of signal noise.

An integrated gas flow meter allows the addition of a second Ar gas flow after the PTFE membrane; this second gas flow enables the best optimization of washout time and further reduction of signal noise.

Two peristaltic pumps (user provided) are recommended: one pump for sample and reagent addition and one pump to remove liquid waste from the GLS. A general experimental setup for generation of Hg^0 is given in Figure 2.

Figure 2. Experimental Setup

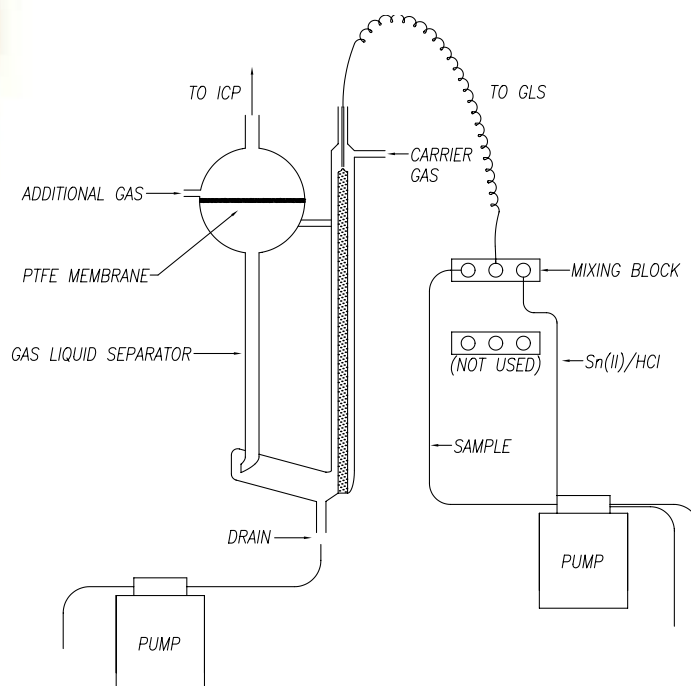

	Pneumatic Nebulization	CETAC HGX-200
RF Power	1300 W	1300 W
Nebulizer	Crossflow	N/A
Spray Chamber	Cylindrical	N/A
Solution(s) Uptake	1.0 mL/min	2.0 mL/min
Carrier Gas	0.91 L/min	0.33 L/min
Additional Argon Gas	0.14 L/min	0.65 L/min
Integration Time	9 s	9 s
Replicates	7	7

Note: Agilent 4500 ICP-MS

Important Notes:

When using the HGX-200, the additional Ar gas was added to the gas port after the PTFE membrane. The carrier gas flow was connected to pass through the GLS (just above the “frosted” glass post). Note the lower carrier gas flow, (0.33 L/min), used when passing the carrier gas through the GLS.

A dedicated reagent bottle was used for the SnCl₂ solution. The solution consisted of 2% SnCl₂ in 7% (v/v) HCl. The reagent bottle is equipped with a gas port and check valve to purge any traces of Hg in the reagent. This is typically done for 20 to 30 minutes with an Ar gas flow of approximately 0.5 L/min.

Results:

Use of the HGX-200 provides a significant increase in the mercury signal (counts per second per ppb) versus a standard pneumatic (crossflow) nebulizer due to the high efficiency of the reduction reaction with SnCl₂.

Element	m/z	Pneumatic Nebulization	HGX-200	Improvement Factor
Hg	202	5,240 cps/ppb	113,600 cps/ppb	22

A comparison of instrument detection limits (IDLs) for ²⁰²Hg shows an improvement of up to 40 times with the HGX-200. The IDLs are given in units of ng/L. The improvement is due to a combination of higher signal and lower background noise.

Element	m/z	Pneumatic Nebulization	HGX-200	Improvement Factor
Hg	202	4	0.1	40

CETAC Technologies
14306 Industrial Road
Omaha, NE 68144
800-369-2822
402-733-2829
www.cetac.com